

DEMU BOLT ANCHORS

EUROPEAN TECHNICAL APPROVAL ETA-13/0401



DEMU FIXING ANCHORS

ETA_DEMU-BA 06/13-E

CONCRETE



HALFEN
YOUR BEST CONNECTIONS

DEMU BOLT ANCHORS

General note

Use of third-party products

This approval only applies to original HALFEN products manufactured by HALFEN. The specifications in this approval are not transferable to other products. Users are fully liable for personal injuries and material damage caused by third-party products used instead of HALFEN products.

Deutsches Institut für Bautechnik
Zulassungsstelle für Bauprodukte und Bauarten
Bautechnisches Prüfamts

Eine vom Bund und den Ländern
gemeinsam getragene Anstalt des
öffentlichen Rechts

Kolonnenstraße 30 B
D-10829 Berlin
Tel.: +49 30 78730-0
Fax: +49 30 78730-320
E-Mail: dibt@dibt.de
www.dibt.de

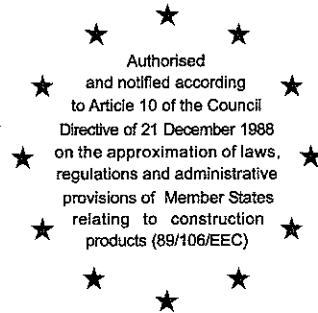

Deutsches
Institut
für
Bautechnik



Mitglied der EOTA
Member of EOTA



European Technical Approval ETA-13/0401

English translation prepared by DIBt - Original version in German language

Handelsbezeichnung
Trade name

DEMU Bolzenanker
DEMU Bolt anchor

Zulassungsinhaber
Holder of approval

Halfen GmbH
Liebigstraße 14
40764 Langenfeld
DEUTSCHLAND

Zulassungsgegenstand
und Verwendungszweck
*Generic type and use
of construction product*

Einbetonierter Anker mit Innengewindehülse
Cast-in anchor with internal threaded socket

Geltungsdauer:
Validity: vom
from
bis
to

13 June 2013
13 June 2018

Herstellwerk
Manufacturing plant

Werk Utrecht
Atoomweg 1
3542 Utrecht
Niederlande

Diese Zulassung umfasst
This Approval contains

20 Seiten einschließlich 13 Anhänge
20 pages including 13 annexes



Europäische Organisation für Technische Zulassungen
European Organisation for Technical Approvals

I LEGAL BASES AND GENERAL CONDITIONS

- 1 This European technical approval is issued by Deutsches Institut für Bautechnik in accordance with:
 - Council Directive 89/106/EEC of 21 December 1988 on the approximation of laws, regulations and administrative provisions of Member States relating to construction products¹, modified by Council Directive 93/68/EEC² and Regulation (EC) N° 1882/2003 of the European Parliament and of the Council³;
 - *Gesetz über das In-Verkehr-Bringen von und den freien Warenverkehr mit Bauprodukten zur Umsetzung der Richtlinie 89/106/EWG des Rates vom 21. Dezember 1988 zur Angleichung der Rechts- und Verwaltungsvorschriften der Mitgliedstaaten über Bauprodukte und anderer Rechtsakte der Europäischen Gemeinschaften (Bauproduktengesetz - BauPG) vom 28. April 1998⁴, as amended by Article 2 of the law of 8 November 2011⁵;*
 - Common Procedural Rules for Requesting, Preparing and the Granting of European technical approvals set out in the Annex to Commission Decision 94/23/EC⁶.
- 2 Deutsches Institut für Bautechnik is authorized to check whether the provisions of this European technical approval are met. Checking may take place in the manufacturing plant. Nevertheless, the responsibility for the conformity of the products to the European technical approval and for their fitness for the intended use remains with the holder of the European technical approval.
- 3 This European technical approval is not to be transferred to manufacturers or agents of manufacturers other than those indicated on page 1, or manufacturing plants other than those indicated on page 1 of this European technical approval.
- 4 This European technical approval may be withdrawn by Deutsches Institut für Bautechnik, in particular pursuant to information by the Commission according to Article 5(1) of Council Directive 89/106/EEC.
- 5 Reproduction of this European technical approval including transmission by electronic means shall be in full. However, partial reproduction can be made with the written consent of Deutsches Institut für Bautechnik. In this case partial reproduction has to be designated as such. Texts and drawings of advertising brochures shall not contradict or misuse the European technical approval.
- 6 The European technical approval is issued by the approval body in its official language. This version corresponds fully to the version circulated within EOTA. Translations into other languages have to be designated as such.

¹ Official Journal of the European Communities L 40, 11 February 1989, p. 12

² Official Journal of the European Communities L 220, 30 August 1993, p. 1

³ Official Journal of the European Union L 284, 31 October 2003, p. 25

⁴ *Bundesgesetzblatt Teil I 1998*, p. 812

⁵ *Bundesgesetzblatt Teil I 2011*, p. 2178

⁶ Official Journal of the European Communities L 17, 20 January 1994, p. 34

II SPECIFIC CONDITIONS OF THE EUROPEAN TECHNICAL APPROVAL

1 Definition of product and intended use

1.1 Definition of the construction product

The DEMU bolt anchor in the size of M12, M16, M20, M24, M30, M36 and M42 as type 1985 and 1988 is an anchor consisting of a bolt and an internal threaded socket screwed and pressed on the thread of the bolt.

The socket is made of electroplated steel, hot-dipped galvanised steel or stainless steel.

The anchor may be imbedded surface-flush or sunk in the concrete.

An illustration of the product and intended use is given in Annex 1.

1.2 Intended use

The anchor is intended to be used for anchorages for which requirements for mechanical resistance and stability and safety in use in the sense of the Essential Requirements 1 and 4 of Council Directive 89/106/EEC shall be fulfilled and failure of anchorages made with these products would cause risk to human life and/or lead to considerable economic consequences.

The anchor is to be used only for anchorages subject to static or quasi-static loading in reinforced or unreinforced normal weight concrete of strength classes C20/25 at minimum to C50/60 at most according to EN 206-1:2000-12. The anchor may be anchored in cracked and non-cracked concrete.

The anchor may be used for transmission of tensile loads, shear loads or a combination of tensile and shear loads.

The intended use of the anchor (anchor, washer, screw) concerning corrosion is given in Annex 5, Table 5 depending on the chosen material.

The anchor made of electroplated steel and hot-dipped galvanised steel and the anchor made of stainless steel without sealing of the bottom of the sleeve may only be used if the inner area of the socket is protected against water.

The provisions made in this European technical approval are based on an assumed working life of the anchor of 50 years. The indications given on the working life cannot be interpreted as a guarantee given by the producer, but are to be regarded only as a means for choosing the right products in relation to the expected economically reasonable working life of the works.

2 Characteristics of the product and methods of verification

2.1 Characteristics of the product

The anchor corresponds to the drawings and information given in Annex 2 to 4. The characteristic material values, dimensions and tolerances of the anchor not indicated in the Annexes shall correspond to respective values laid down in the technical documentation⁷ of this European technical approval.

⁷ The technical documentation of this European technical approval is deposited at Deutsches Institut für Bautechnik and, as far as it is relevant to the tasks of the approved body involved in the attestation of conformity procedure, is handed over to the approved bodies.

Regarding the requirements concerning safety in case of fire it is assumed that the anchor meets the requirements of class A1 in relation to reaction to fire in accordance with the stipulations of the Commission decision 96/603/EC, amended by 2000/605/EC.

The characteristic values for the design of the anchorages are given in Annexes 7 to 11.

The anchor shall be marked with the identifying mark of the producer, the name of the anchor, the size and the material, e.g. "DEMU 1988 M16x140 GV" according to Annex 4.

2.2 Method of verification

2.2.1 General

The assessment of the fitness of the anchor for the intended use with regard to the requirements of mechanical resistance and stability as well as safety in use in the sense of the Essential Requirements 1 and 4 was performed based on the following verifications:

Verifications for tension loads for

- | | |
|---|-----------------------------|
| 1. Steel failure | $N_{Rk,s}$ |
| 2. Steel failure - transfer of setting torque into prestressing force | T_{inst} |
| 3. Concrete failure - pullout | $N_{Rk,p}$ |
| 4. Concrete failure - concrete cone | $N_{Rk,c}$ |
| 5. Concrete failure - splitting due to installation | $c_{min}, s_{min}, h_{min}$ |
| 6. Concrete failure - splitting due to loading | $N_{Rk,sp}$ |
| 7. Displacement under tension loads | δ_N |

Verifications for shear loads for

- | | |
|-------------------------------------|--------------|
| 1. Steel failure without lever arm | $V_{Rk,s}$ |
| 2. Steel failure with lever arm | $M_{Rk,s}^0$ |
| 3. Concrete failure - pry-out | $V_{Rk,cp}$ |
| 4. Concrete failure - concrete edge | $V_{Rk,c}$ |
| 5. Displacement under shear loads | δ_V |

In addition to the specific clauses relating to dangerous substances contained in this European technical approval, there may be other requirements applicable to the products falling within its scope (e.g. transposed European legislation and national laws, regulations and administrative provisions). In order to meet the provisions of the Construction Products Directive, these requirements need also to be complied with, when and where they apply.

3 Evaluation and attestation of conformity and CE marking

3.1 System of attestation of conformity

According to the Decision 96/582/EC of the European Commission⁸ system 2(i) (referred to as system 1) of the attestation of conformity applies.

This system of attestation of conformity is defined as follows:

System 1: Certification of the conformity of the product by an approved certification body on the basis of:

- (a) Tasks for the manufacturer:
- (1) factory production control;

⁸ Official Journal of the European Communities L 254 of 08.10.1996

- (2) further testing of samples taken at the factory by the manufacturer in accordance with a prescribed test plan;
- (b) Tasks for the approved body:
 - (3) initial type-testing of the product;
 - (4) initial inspection of factory and of factory production control;
 - (5) continuous surveillance, assessment and approval of factory production control.

Note: Approved bodies are also referred to as "notified bodies".

3.2 Responsibilities

3.2.1 Tasks for the manufacturer

3.2.1.1 Factory production control

The manufacturer shall exercise permanent internal control of production. All the elements, requirements and provisions adopted by the manufacturer shall be documented in a systematic manner in the form of written policies and procedures, including records of results performed. This production control system shall insure that the product is in conformity with this European technical approval.

The manufacturer may only use initial/raw/constituent material stated in the technical documentation of this European technical approval.

The factory production control shall be in accordance with the control plan which is part of the technical documentation of this European technical approval. The control plan is laid down in the context of the factory production control system operated by the manufacturer and deposited with Deutsches Institut für Bautechnik.⁹

The results of factory production control shall be recorded and evaluated in accordance with the provisions of the control plan.

3.2.1.2 Other tasks for the manufacturer

The manufacturer shall, on the basis of a contract, involve a body which is approved for the tasks referred to in section 3.1 in the field of anchors in order to undertake the actions laid down in section 3.2.2. For this purpose, the control plan referred to in sections 3.2.1.1 and 3.2.2 shall be handed over by the manufacturer to the approved body involved.

The manufacturer shall make a declaration of conformity, stating that the construction product is in conformity with the provisions of this European technical approval.

3.2.2 Tasks for the approved bodies

The approved body shall perform the

- initial type-testing of the product,
- initial inspection of factory and of factory production control,
- continuous surveillance, assessment and approval of factory production control,

in accordance with the provisions laid down in the control plan.

The approved body shall retain the essential points of its actions referred to above and state the results obtained and conclusions drawn in a written report.

The approved certification body involved by the manufacturer shall issue an EC certificate of conformity of the product stating the conformity with the provisions of this European technical approval.

⁹

The control plan is a confidential part of the European technical approval and only handed over to the approved body involved in the procedure of attestation of conformity. See section 3.2.2.

In cases where the provisions of the European technical approval and its control plan are no longer fulfilled the certification body shall withdraw the certificate of conformity and inform Deutsches Institut für Bautechnik without delay.

3.3 CE marking

The CE marking shall be affixed on each packaging of the anchor. The letters "CE" shall be followed by the identification number of the approved certification body, where relevant, and be accompanied by the following additional information:

- the name and address of the producer (legal entity responsible for the manufacture),
- the last two digits of the year in which the CE marking was affixed,
- the number of the EC certificate of conformity for the product,
- the number of the European technical approval,
- size.

4 Assumptions under which the fitness of the product for the intended use was favourably assessed

4.1 Manufacturing

The European technical approval is issued for the product on the basis of agreed data/information, deposited with Deutsches Institut für Bautechnik, which identifies the product that has been assessed and judged. Changes to the product or production process, which could result in this deposited data/information being incorrect, should be notified to Deutsches Institut für Bautechnik before the changes are introduced. Deutsches Institut für Bautechnik will decide whether or not such changes affect the approval and consequently the validity of the CE marking on the basis of the approval and if so whether further assessment or alterations to the approval shall be necessary.

4.2 Design of anchorages

The fitness of the anchor for the intended use is given under the following condition:

The design of the anchorage is based on the CEN/TS 1992-4:2009 "Design of fastenings for use in concrete", part 1 and 2 under the responsibility of an engineer experienced in anchorages and concrete work.

The screw is chosen with corresponding screw-in depth acc. Annex 6, Table 6 and strength grade acc. Annex 8, 10 and 11 subject to the required steel resistance.

The member thickness is not less than h_{min} . The edge distance of the anchors is not less than c_{min} . The spacing of the anchors is not less than s_{min} . All these values are indicated in Annex 7, Table 7 subject to the size of the anchor.

Taking into account the loads to be anchored verifiable calculation notes and drawings are generated.

The position, the name, the size of the anchor, if applicable the supplementary reinforcement and the size, the screw-in depth and the strength grade of the screw are indicated on the design drawings. The material of the anchor and the screw shall be given additionally on the drawings.

4.3 Installation of the anchor

The fitness for use of the anchor can only be assumed, if the following installation conditions are observed:

- Installation by appropriately qualified personnel and under the supervision of the person responsible for technical matters on site.
- Use of the anchor only as supplied by the manufacturer without any manipulation or exchanging the components.
- Installation in accordance with the manufacturer's specifications given in Annex 12 and 13 and the design drawings.
- The anchors are fixed on the formwork so that no movement of the anchors will occur during the time of laying the reinforcement and of placing and compacting the concrete.
- The concrete among the anchor and especially under the head of the foot-mounted anchor is properly compacted.
- The sockets are protected from penetration of concrete, for sockets made of electroplated steel and hot-dipped galvanised steel and sockets made of stainless steel without sealing from penetration of water into the internal space of the sockets.
- Size, material and strength grade of screws corresponding to the design drawings.
- Observation of the prescribed values (e.g. T_{inst} according Annex 6) of installation.
- The setting torques given in Annex 6 must not be exceeded.

5 Responsibility of the manufacturer

It is in the responsibility of the manufacturer to ensure that the information on the specific conditions according to 1 and 2 including Annexes referred to and 4.2 and 4.3 is given to those who are concerned. This information may be made by reproduction of the respective parts of the European technical approval. In addition all installation data shall be shown clearly on the package and/or on an enclosed instruction sheet, preferably using illustration(s).

The minimum data required are:

- Dimensions of the anchor,
- Material of the socket,
- Mentioning the matching screw,
- Details on the installation procedure, preferably by using illustrations,
- Maximum setting torque,
- Identification of the manufacturing batch.

All data shall be presented in a clear and explicit form.

Andreas Kummerow
p. p. Head of Department

beglaubigt:
Müller

DEMU Bolt anchor

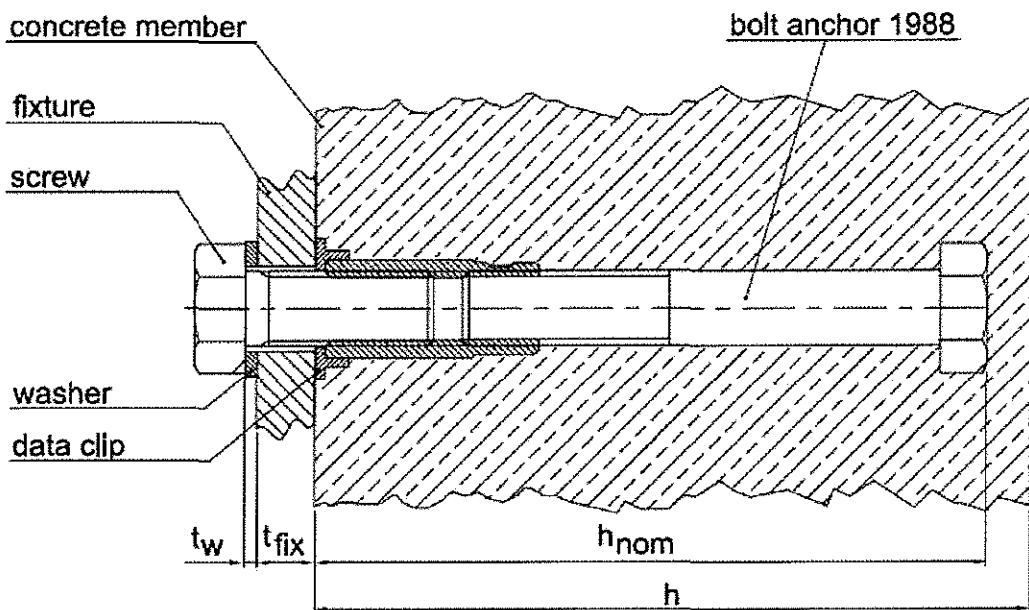
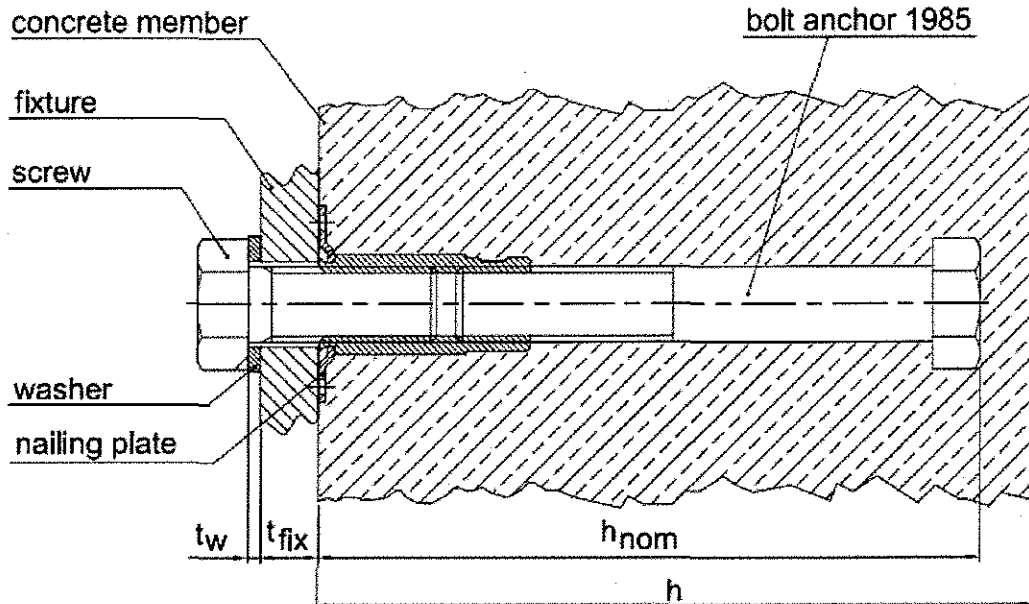

- h = thickness of concrete member
- t_{fix} = thickness of fixture
- t_w = thickness of washer
- h_{nom} = embedment depth

DEMU Bolt anchor

Product and intended use

Annex 1

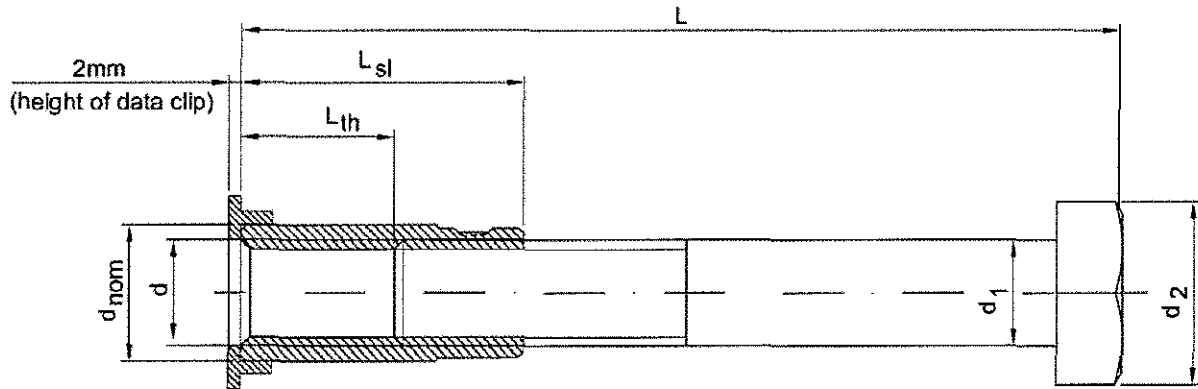

There are 4 different materials available for the DEMU Bolt anchor 1988:

Material 1: Sleeve electroplated

Material 2: Sleeve hot-dipped galvanised

Material 3: Sleeve in stainless steel A4-50

Material 4: Sleeve in stainless steel A4-80

Table 1: Dimensions of DEMU Bolt anchor 1988 with sleeves made of material 1 or 2

d	d _{nom}	L _{sl}	L _{th}	d ₁	d ₂	L
[mm]	[mm]	[mm]	[mm]	[mm]	[mm]	[mm]
M12	15.5	35.0	23.0 - 25.4	12.0	18.0	55 / 100 / 150
M16	21.0	45.0	29.0 - 32.2	16.0	24.0	75 / 140 / 220
M20	26.0	55.0	35.0 - 39.0	20.0	30.0	90 / 150 / 180 / 270
M24	32.0	70.0	46.0 - 50.8	24.0	36.0	110 / 200 / 320
M30	40.0	90.0	60.0 - 66.0	30.0	46.0	160 / 240 / 380
M36	47.5	110.0	74.0 - 81.2	36.0	55.0	300 ¹⁾ / 420
M42	54.0	110.0	68.0 - 76.4	42.0	65.0	300 ¹⁾ / 460 ¹⁾

¹⁾ only available with sleeve made of material 1

Table 2: Dimensions of DEMU Bolt anchor 1988 with sleeves made of material 3 or 4

d	d _{nom}	L _{sl}	L _{th}	d ₁	d ₂	L
[mm]	[mm]	[mm]	[mm]	[mm]	[mm]	[mm]
M12	15.5 / 16.0 ²⁾	35.0	23.0 - 25.4	12.0	18.0	100 / 150
M16	21.0 / 21.3 ²⁾	45.0	29.0 - 32.2	16.0	24.0	140 / 220
M20	26.0	55.0	35.0 - 39.0	20.0	30.0	150 / 180 / 270
M24	32.0	70.0	46.0 - 50.8	24.0	36.0	200 ³⁾
M30	40.0	90.0	60.0 - 66.0	30.0	46.0	240 ³⁾

²⁾ higher value applies for material 3; ³⁾ only available with sleeve made of material 4

DEMU Bolt anchor

Dimensions type 1988

Annex 2

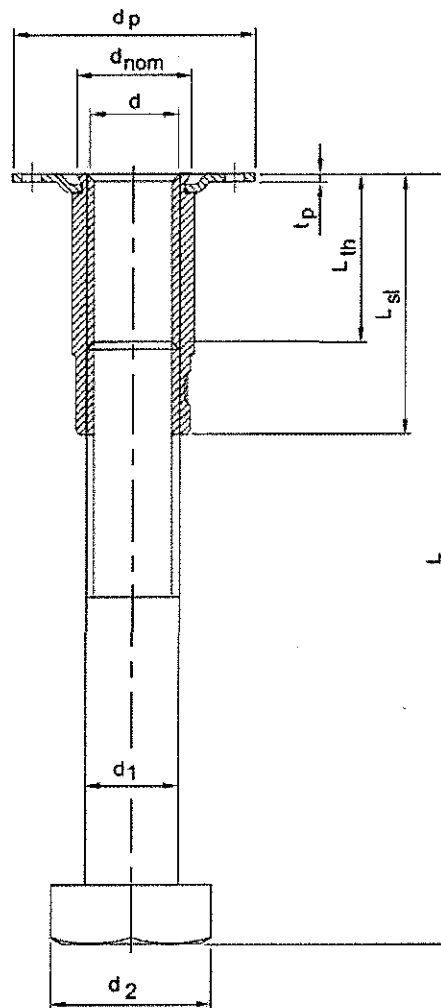

The bolt anchor 1985 is available with a sleeve made of the following material:

Material 1: Sleeve electroplated

Table 3: Dimensions of DEMU Bolt anchor 1985 with sleeve / nailing plate made of material 1

d	d _{nom}	L _{st}	L _{th}	d ₁	d ₂	L	d _p	t _p
[mm]	[mm]	[mm]	[mm]	[mm]	[mm]	[mm]	[mm]	[mm]
M12	15.5	35.0	23.0 - 25.4	12.0	18.0	150	40.0	1.0
M16	21.0	45.0	29.0 - 32.2	16.0	24.0	140	44.0	1.5
M20	26.0	55.0	35.0 - 39.0	20.0	30.0	180	48.2	1.5
M24	32.0	70.0	46.0 - 50.8	24.0	36.0	200	57.0	1.5

DEMU Bolt anchor

Dimensions type 1985

Annex 3

bolt anchor 1988

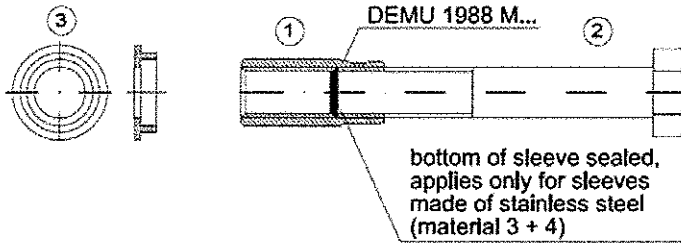

Marking:

e.g.: DEMU 1988 M16x140 GV

DEM U: identifying mark of the producer
1988: name of the anchor
M16x140: size
GV: material

Material:

GV: sleeve electroplated
FV: sleeve hot-dipped galvanised
A4-50: sleeve made of stainless steel A4-50
A4-80: sleeve made of stainless steel A4-80

bolt anchor 1985

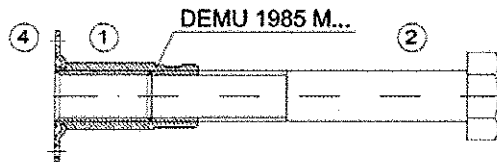

Table 4: Marking/specification and materials of bolt anchor

Item	Component	Material 1	Material 2
		Sleeve in electroplated steel (GV)	Sleeve in hot-dipped galvanised steel (FV)
1	Sleeve	Mecaval 147M +N, E355 +N (1.0580), 20MnV6 +N (1.5217), acc. EN 10305-1, electroplated ¹⁾	Mecaval 147M +N, E355 +N (1.0580), 20MnV6 +N (1.5217), acc. EN 10305-1, hot-dipped galvanised ²⁾
2	Bolt	Hexagon head bolts acc. DIN 931 respect. hexagon head screws with thread up to the head acc. DIN 933, strength grade 8.8	
3	Dataclip	for sleeve made of material 1+2: HDPE / RAL 7035 / (light-) grey	
4	Nailing plate	Sheet steel DC01 (1.0330), acc. EN 10130, electroplated ¹⁾	---
Item	Component	Material 3	Material 4
		Sleeve in stainless steel A4-50	Sleeve in stainless steel A4-80
1	Sleeve	Stainless steel 1.4401 / 1.4404 / 1.4571 / 1.4362, acc. EN 10088-3, bottom of sleeve sealed ³⁾	Stainless steel 1.4401 / 1.4404 / 1.4571 / 1.4362, acc. EN 10216-5, bottom of sleeve sealed ³⁾
2	Bolt	Hexagon head bolts acc. DIN 931 respect. hexagon head screws with thread up to the head acc. DIN 933, strength grade 8.8, hot-dipped galvanised ⁴⁾	
3	Dataclip	for sleeve made of material 3: HDPE / RAL 9003 / (signal-) white	for sleeve made of material 4: HDPE / RAL 9005 / (jet-) black

¹⁾ thickness of coating $\geq 5 \mu\text{m}$ acc. EN ISO 4042
²⁾ thickness of coating $\geq 50 \mu\text{m}$ acc. EN ISO 1461
³⁾ protection of the front end of the bolt against corrosion; for corrosion resistance requirements according to level 3a) mentioned in Annex 5, Table 5, the sealing may be omitted
⁴⁾ thickness of coating $\geq 40 \mu\text{m}$ acc. EN ISO 10684

DEM U Bolt anchor

Marking and materials

Annex 4

Table 5: Materials and intended use
(washer, screw and suppl. reinforcement not included with the fixing system)

		Intended use			
		1	2	3	
1	Specification	Bolt anchors may only be used in structures subject to dry internal conditions (e. g. accommodations, bureaus, schools, hospitals, shops).	Low corrosion exposure Bolt anchors may also be used in structures in unheated / uninsulated buildings where condensation may occur (e. g. warehouses, sport halls), as well as in structures not exposed to rain in outside atmosphere with low level of pollution (mostly rural areas).	Medium corrosion exposure Bolt anchors may also be used in structures subject to external atmospheric exposure (including industrial and marine environment) or exposure in permanently damp internal conditions, if no particular aggressive conditions (e. g. permanent, alternating immersion in seawater) exist.	
				3a	3b
				Moderate level	Increased level
				Medium exposure to chlorides, i. e. sufficient distance from the sea (> 1km) and offside from roads with road salt application (> 10m); with contact to low acidic substances (pH > 3); low exposure to sulfur, nitrogen (urban atmosphere).	High exposure to chlorides, e. g. inshore (≤ 1km) or next to busy roads with road salt application (≤ 10m); exposure to acids (pH ≤ 3); medium exposure to sulfur, nitrogen (industrial area); non-accessible structures (e. g. rear ventilated facades).
Materials					
2	Bolt anchor	Bolt anchor acc. Table 4, material 1 ¹⁾	Bolt anchor acc. Table 4, material 2 ¹⁾	Bolt anchor acc. Table 4, material 3 and 4, without sealing of the bottom of the sleeve ¹⁾	Bolt anchor acc. Table 4, material 3 and 4, with special sealing of the bottom of the sleeve
3	Washer acc. EN ISO 7089/7093-1	Steel acc. EN 10025, galvanised ²⁾	Steel acc. EN 10025, hot-dipped galvanised ³⁾	Stainless steel 1.4401 / 1.4404 / 1.4571 / 1.4362 acc. EN 10088	
4	Screw	Steel acc. EN ISO 898-1, galv. ²⁾ , strength grade 4.6, 5.6 or 8.8	Steel acc. EN ISO 898-1, hot-dipped galv. ³⁾ , strength grade 4.6, 5.6 or 8.8	Stainless steel 1.4401 / 1.4404 / 1.4571 / 1.4362 acc. EN ISO 3506-1, strength grade A4-50, A4-70 or A4-80	
5	Suppl. Reinforcement	B500A or B500B	B500A or B500B	Stainless reinforcement steel 1.4571 / 1.4362 / 1.4462 respect. B500A or B500B meeting the requirements for concrete cover c_{nom} acc. EN 1992-1	

¹⁾ the inner area of the socket has to be protected against ingress of water, e. g. by using DEMU sealing cap or a screw acc. line 4
²⁾ thickness of coating ≥ 5µm acc. EN ISO 4042
³⁾ thickness of coating ≥ 40µm acc. EN ISO 10684

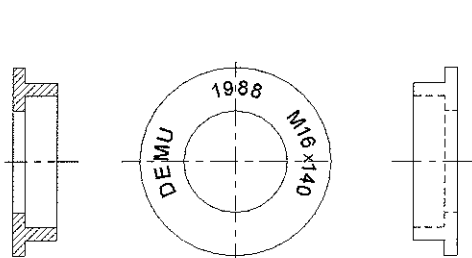

Data clip: section, top view (with example for marking) and side view

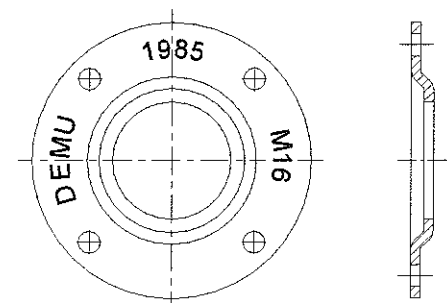

Nailing plate: top view (with example for marking) and section

DEMU Bolt anchor

Materials and intended use, marking

Annex 5

Direct contact between fixture and data clip / nailing plate

The fixture is braced to data clip / nailing plate, if necessary by suitable washer.

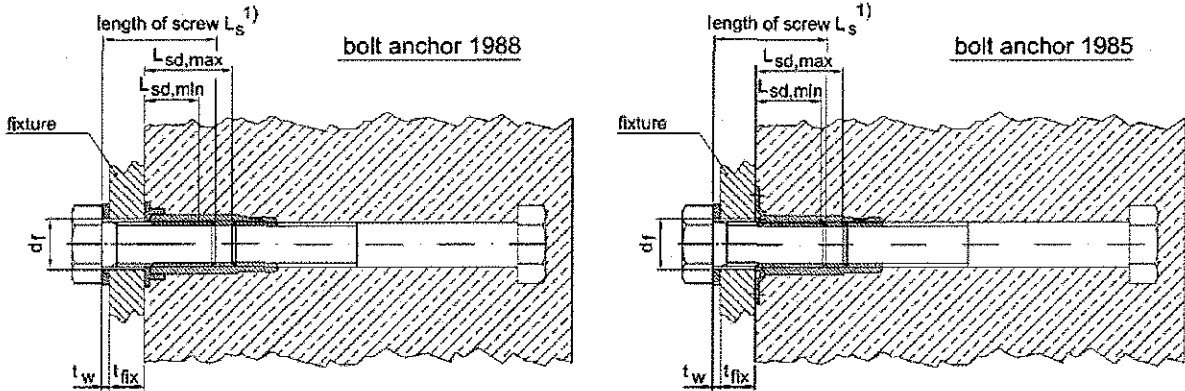

$$1) t_w + t_{fix} + L_{sd,min} \leq L_s \leq t_w + t_{fix} + L_{sd,max}$$

General application

The fixture is braced to concrete (anchor is embedded sunk in the concrete) resp. braced to concrete and dataclip / nailing plate (anchor is embedded flush in the concrete).

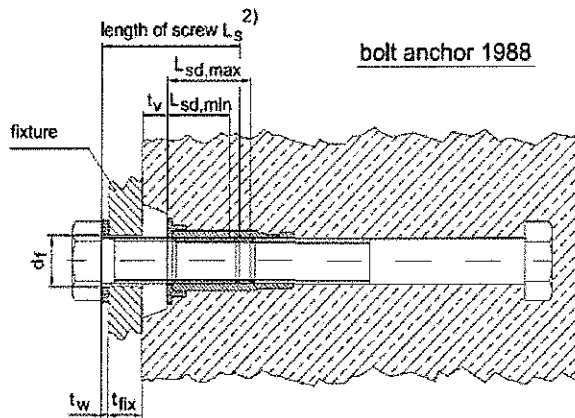

$$2) t_w + t_{fix} + t_v + L_{sd,min} \leq L_s \leq t_w + t_{fix} + t_v + L_{sd,max}$$

Thread size	d	[mm]	M12	M16	M20	M24	M30	M36	M42
Maximum torque moment	max. T _{inst}	[Nm]	≤ 10	≤ 30	≤ 50	≤ 90	≤ 180	≤ 250	≤ 300
Minimum screw-in length - 1988	L _{sd,min}	[mm]	16.4	21.2	26.0	30.8	38.0	45.2	52.4
Minimum screw-in length - 1985	L _{sd,min}	[mm]	18.0	24.0	30.0	36.0			
Maximum screw-in length - 1988	L _{sd,max} ¹⁾	[mm]	25.0	31.0	37.0	48.0	62.0	76.0	70.0
Maximum screw-in length - 1985	L _{sd,max}	[mm]	23.0	29.0	35.0	46.0			
Diameter of clearance hole in fixture	d _f	[mm]	14.0	18.0	22.0	26.0	33.0	39.0	45.0

¹⁾ For bolt anchors with sealing on bottom of sleeve (material 3 + 4) the values have to be decreased by 3.0 mm.

DEMU Bolt anchor

Positions of the fixture
Installation parameters

Annex 6

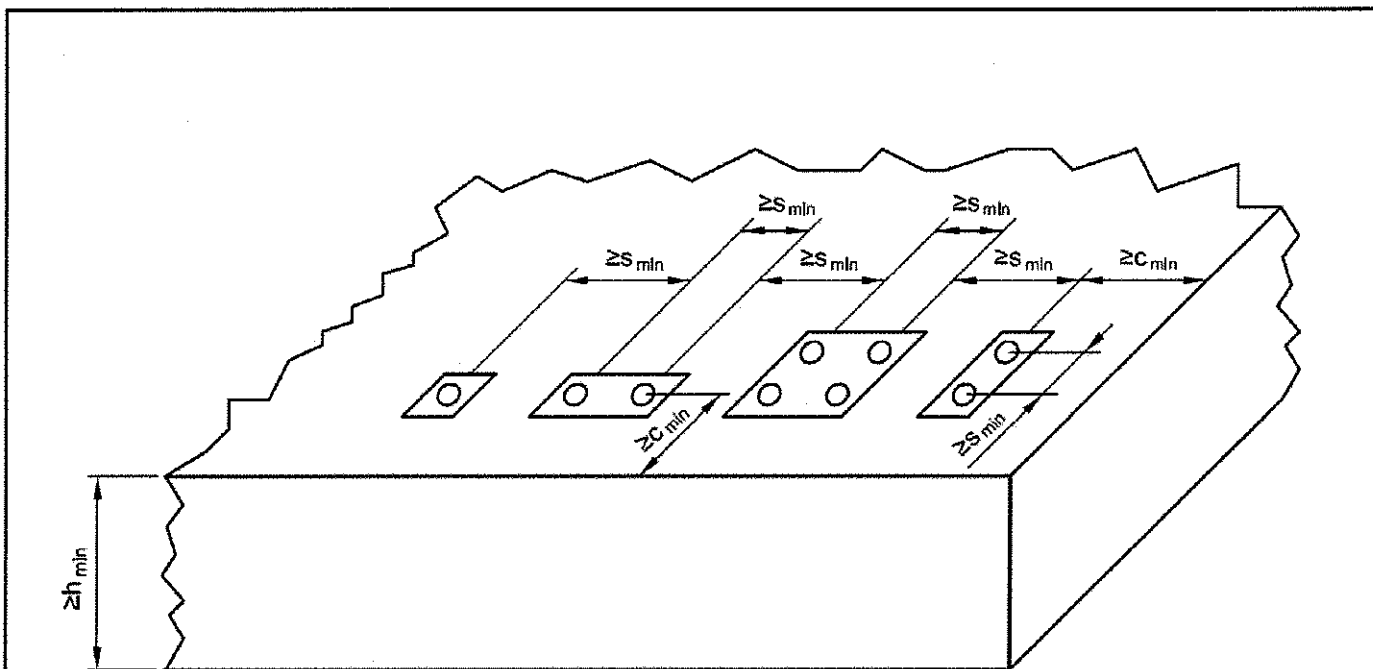

The mentioned spacings, edge distances and member thicknesses apply also for anchors installed in the front edge.

Table 7: Min. thickness of concrete member, min. edge distances and spacing

Thread size	d	[mm]	M12	M16	M20	M24	M30	M36	M42
Minimum spacing	s_{min}	[mm]	100	100	120	150	180	220	260
Minimum edge distance	c_{min}	[mm]	50	50	60	75	90	110	130
Minimum thickness of concrete member	h_{min}	[mm]	$h_{nom} + c_{nom}^{1)}$						

¹⁾ c_{nom} acc. EN 1992-1 with $c_{nom} \geq 20$

DEMU Bolt anchor

Arrangement of anchors and member thickness

Annex 7

Table 8a: Characteristic values for tension loads

Thread size	d	[mm]	M12	M16	M20	M24	M30	M36	M42
Steel failure, bolt anchor (material 1 or 2) and screw (min. steel strength 4.6) made of electroplated / hot-dipped galvanised steel	$N_{Rk,p}$	[kN]	33.7	62.8	98.0	141.2	224.4	326.8	448.4 ²⁾
Characteristic resistance	$N_{Rk,p}$	[kN]	33.7	62.8	98.0	141.2	224.4	326.8	448.4 ²⁾
Partial safety factor	γ_{Ms}	[-]	2.00						
Steel failure, bolt anchor (material 1 or 2) and screw (min. steel strength 5.6) made of electroplated / hot-dipped galvanised steel	$N_{Rk,p}$	[kN]	42.2	78.5	122.5	176.5	280.5	408.5	560.5 ²⁾
Characteristic resistance	$N_{Rk,p}$	[kN]	42.2	78.5	122.5	176.5	280.5	408.5	560.5 ²⁾
Partial safety factor	γ_{Ms}	[-]	2.00						
Steel failure, bolt anchor (material 1 or 2) and screw (min. steel strength 8.8) made of electroplated / hot-dipped galvanised steel	$N_{Rk,p}$	[kN]	45.8	93.1	139.6	219.5	335.0	490.5	588.1 ²⁾
Characteristic resistance	$N_{Rk,p}$	[kN]	45.8	93.1	139.6	219.5	335.0	490.5	588.1 ²⁾
Partial safety factor	γ_{Ms}	[-]	1.58						
Steel failure, bolt anchor (material 3: A4-50) and screw (min. steel strength A4-50) made of stainless steel	$N_{Rk,s}$	[kN]	42.2	81.0	110.3				
Characteristic resistance	$N_{Rk,s}$	[kN]	42.2	81.0	110.3				
Partial safety factor	γ_{Ms}	[-]	2.86						
Steel failure, bolt anchor (material 3: A4-50) and screw (min. steel strength A4-70, A4-80) made of stainless steel	$N_{Rk,s}$	[kN]	46.4	81.0	110.3				
Characteristic resistance	$N_{Rk,s}$	[kN]	46.4	81.0	110.3				
Partial safety factor	γ_{Ms}	[-]	3.09						
Steel failure, bolt anchor (material 4: A4-80) and screw (min. steel strength A4-80) made of stainless steel	$N_{Rk,s}$	[kN]	59.0	125.6	180.1	282.4	448.8		
Characteristic resistance	$N_{Rk,s}$	[kN]	59.0	125.6	180.1	282.4	448.8		
Partial safety factor	γ_{Ms}	[-]	1.48						
Pull-out failure									
Charact. resistance in cracked concrete	$N_{Rk,p}$	[kN]	25.1	44.7	69.8	100.5	168.9	240.3	341.0
Charact. resistance in uncracked concrete	$N_{Rk,p}$	[kN]	35.2	62.5	97.7	140.7	236.4	336.4	477.4
Increasing factors for $N_{Rk,p}$ in cracked and uncracked concrete	ψ_c	[-]	1.20						
	ψ_e	[-]	1.48						
	ψ_c	[-]	1.80						
	ψ_e	[-]	2.00						
	ψ_c	[-]	2.20						
	ψ_e	[-]	2.40						
Partial safety factor	γ_{Mpb}	[-]	1.50						

¹⁾ in absence of other national regulations; ²⁾ only available in GV (material 1 acc. to Annex 4)

DEMU Bolt anchor

Characteristic values for tension loads

Annex 8

Table 8b: Characteristic values for tension loads

Thread size	d	[mm]	M12	M16	M20	M24	M30	M36	M42							
Concrete cone failure																
Effective anchorage depth	h_{ef}^1	[mm]	M12x55:	49.0	M16x75:	67.0	M20x90:	79.0	M24x110:	97.0	M30x160:	143.0	M36x300:	279.0	M42x300:	276.0
			M12x100:	94.0	M16x140:	132.0	M20x150:	139.0	M24x200:	187.0	M30x240:	223.0	M36x420:	399.0	M42x460:	436.0
			M12x150:	144.0	M16x220:	212.0	M20x180:	169.0	M24x320:	307.0	M30x380:	363.0				
Factor to take into account the influence of load transfer mechanisms in cracked and uncracked concrete	k_{tr}	[-]	8.5													
			11.9													
Characteristic spacing	$s_{cr,N}$	[mm]	$3.0 \cdot h_{ef}$													
Characteristic edge distance	$c_{cr,N}$	[mm]	$1.5 \cdot h_{ef}$													
Partial safety factor	γ_{M2}^2	[-]	1.50													
Splitting																
Effective anchorage depth	h_{ef}^1	[mm]	M12x55:	49.0	M16x75:	67.0	M20x90:	79.0	M24x110:	97.0	M30x160:	143.0	M36x300:	279.0	M42x300:	276.0
			M12x100:	94.0	M16x140:	132.0	M20x150:	139.0	M24x200:	187.0	M30x240:	223.0	M36x420:	399.0	M42x460:	436.0
			M12x150:	144.0	M16x220:	212.0	M20x180:	169.0	M24x320:	307.0	M30x380:	363.0				
Characteristic spacing	$s_{cr,sp}$	[mm]	$4.0 \cdot h_{ef}$													
Characteristic edge distance	$c_{cr,sp}$	[mm]	$2.0 \cdot h_{ef}$													
Partial safety factor	$\gamma_{M2,sp}^2$	[-]	1.50													

¹⁾ for bolt anchor type 1985 the values have to be decreased by 2.0 mm; ²⁾ in absence of other national regulations

Table 9: Displacements under tension loads

Thread size	d	[mm]	M12	M16	M20	M24	M30	M36	M42
Displacements δ_{Np} to 0.7 mm for short term loading in cracked and uncracked concrete under following tension loads ¹⁾	N	[kN]	14.0	20.0	29.0	40.0	63.0	83.0	113.0

¹⁾ for long term tension loading the displacements δ_{Np} can be increased to 1.8 mm

DEMU Bolt anchor

Characteristic values for tension loads
Displacements under tension loads

Annex 9

Table 10a: Characteristic values for shear loads																		
Thread size	d	[mm]	M12	M16	M20	M24	M30	M36	M42									
Shear loads without lever arm																		
Group factor (CEN/TS 1992-4-2, 6.3.3.1)	k_2	[-]	1.0															
Steel failure, bolt anchor (material 1 or 2), and screw (min. steel strength 4.6) made of electroplated / hot-dipped galvanized steel	$V_{Rk,s}$	[kN]	16.9	31.4	49.0	70.6	112.2	163.4	224.2 ²⁾									
Characteristic resistance	$V_{Rk,s}$	[kN]	1.67															
Partial safety factor	γ_{Ms}	[-]	1.67															
Steel failure, bolt anchor (material 1 or 2), and screw (min. steel strength 5.6) made of electroplated / hot-dipped galvanized steel	$V_{Rk,s}$	[kN]	21.1	39.3	61.3	88.3	140.3	204.3	280.3 ²⁾									
Characteristic resistance	$V_{Rk,s}$	[kN]	1.67															
Partial safety factor	γ_{Ms}	[-]	1.67															
Steel failure, bolt anchor (material 1 or 2), and screw (min. steel strength 8.8) made of electroplated / hot-dipped galvanized steel	$V_{Rk,s}$	[kN]	22.9	46.5	69.8	109.7	167.5	245.2	294.1 ²⁾									
Characteristic resistance	$V_{Rk,s}$	[kN]	1.32															
Partial safety factor	γ_{Ms}	[-]	1.32															
Steel failure, bolt anchor (material 3: A4-50) and screw (min. steel strength A4-50) made of stainless steel	$V_{Rk,s}$	[kN]	21.1	40.5	55.1													
Characteristic resistance	$V_{Rk,s}$	[kN]	2.58															
Partial safety factor	γ_{Ms}	[-]	2.58															
Steel failure, bolt anchor (material 3: A4-50) and screw (min. steel strength A4-70, A4-80) made of stainless steel	$V_{Rk,s}$	[kN]	23.2	40.5	55.1													
Characteristic resistance	$V_{Rk,s}$	[kN]	2.58															
Partial safety factor	γ_{Ms}	[-]	2.58															
Steel failure, bolt anchor (material 4: A4-80) and screw (min. steel strength A4-80) made of stainless steel	$V_{Rk,s}$	[kN]	29.5	62.8	90.0	141.2	224.4											
Characteristic resistance	$V_{Rk,s}$	[kN]	1.23															
Partial safety factor	γ_{Ms}	[-]	1.23															
Shear loads with lever arm: see Annex 10, Table 10b																		
Pry-out failure																		
Factor	k_s	[-]	M12x55:	1.0														
			M12x100:	2.0	2.0	2.0	2.0	2.0										
			M12x150:	2.0														
Partial safety factor	γ_{Nap}	[-]	1.50															
Concrete edge failure (without suppl. reinforcement)																		
Effective length of fixing anchor (for shear loads)	l_f	[mm]	M12x55:	47.0	M16x75:	65.0	M20x80:	77.0	M24x110:	95.0	M30x160:	141.0	M36x300:	277.0	M42x300:	274.0		
			M12x100:	92.0	M16x140:	130.0	M20x150:	137.0	M24x200:	185.0	M30x240:	221.0	M36x420:	380.0	M42x460:	432.0		
			M12x150:	124.0	M16x220:	168.0	M20x180:	167.0	M24x320:	255.0	M30x380:	320.0						
Effective outside diameter	d_{out}	[mm]																
			M20x270:	208.0														
Partial safety factor	γ_{Nap}	[-]	15.5 / 16.0 ³⁾	21.0 / 21.3 ³⁾	26.0	32.0	40.0	47.5	54.0									
			1.50															

¹⁾ in absence of other national regulations; ²⁾ only available in GV (material 1 acc. to Annex 4); ³⁾ higher value applies for material 3

DEMU Bolt anchor

Characteristic values for shear loads

Annex 10

Table 10b: Characteristic values for shear loads

Thread size	d	[mm]	M12	M16	M20	M24	M30	M36	M42
Shear loads with lever arm									
Steel failure, bolt anchor (material 1 or 2) and screw (min. steel strength 4.6) made of electroplated / hot-dipped galvanised steel									
Characteristic resistance	$M_{Rk,s}^d$	[Nm]	52.4	13.2	259.6	449.0	899.6	1581.0	2541.1 ²⁾
Partial safety factor	γ_{vis}	[-]	1.67						
Steel failure, bolt anchor (material 1 or 2) and screw (min. steel strength 5.6) made of electroplated / hot-dipped galvanised steel									
Characteristic resistance	$M_{Rk,s}^d$	[Nm]	65.5	166.5	324.5	561.3	1124.5	1976.3	3176.3 ²⁾
Partial safety factor	γ_{vis}	[-]	1.67						
Steel failure, bolt anchor (material 1 or 2) and screw (min. steel strength 8.8) made of electroplated / hot-dipped galvanised steel									
Characteristic resistance	$M_{Rk,s}^d$	[Nm]	104.8	266.4	519.3	896.0	1799.2	3162.1	5082.1 ²⁾
Partial safety factor	γ_{vis}	[-]	1.25						
Steel failure, bolt anchor (material 3: A4-50) and screw (min. steel strength A4-50) made of stainless steel									
Characteristic resistance	$M_{Rk,s}^d$	[Nm]	65.5	166.5	324.5				
Partial safety factor	γ_{vis}	[-]	2.38						
Steel failure, bolt anchor (material 3: A4-50) and screw (min. steel strength A4-70) made of stainless steel									
Characteristic resistance	$M_{Rk,s}^d$	[Nm]	91.7	383.7	659.4				
Partial safety factor	γ_{vis}	[-]	2.58						
Steel failure, bolt anchor (material 3: A4-50) and screw (min. steel strength A4-80) made of stainless steel									
Characteristic resistance	$M_{Rk,s}^d$	[Nm]	161.6	383.7	659.4				
Partial safety factor	γ_{vis}	[-]	2.58						
Steel failure, bolt anchor (material 4: A4-80) and screw (min. steel strength A4-80) made of stainless steel									
Characteristic resistance	$M_{Rk,s}^d$	[Nm]	104.8	266.4	519.3	896.0	1799.2		
Partial safety factor	γ_{vis}	[-]	1.33						

¹⁾ in absence of other national regulations; ²⁾ only available in GV (material 1 acc. to Annex 4)

Table 11: Displacements under shear loads

Thread size	d	[mm]	M12	M16	M20	M24	M30	M36	M42
Displacements δ_w to 1.5 mm for short term loading in cracked and uncracked concrete under following shear loads ¹⁾	V	[kN]	13.0	23.0	36.0	52.0	82.0	120.0	160.0

¹⁾ for long term shear loading the displacements $\delta_{w,c}$ can be increased to 2.0 mm

DEMU Bolt anchor

Characteristic values for shear loads
Displacements under shear loads

Annex 11

Installation instruction - part 1

1. Scope of delivery

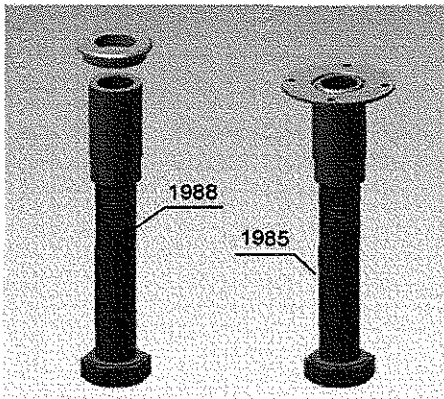

1) Selection of bolt anchor in accordance with the planning documents.

1a) DEMU Bolt anchor 1988 GV / FV / A4-50 / A4-80 or DEMU Bolt anchor 1985 GV

1b) Data clip for bolt anchor 1988 GV / FV, colour: grey;
Data clip for bolt anchor 1988 A4-50, colour: white;
Data clip for bolt anchor 1988 A4-80, colour: black.

2. Fixing of the anchor to the formwork

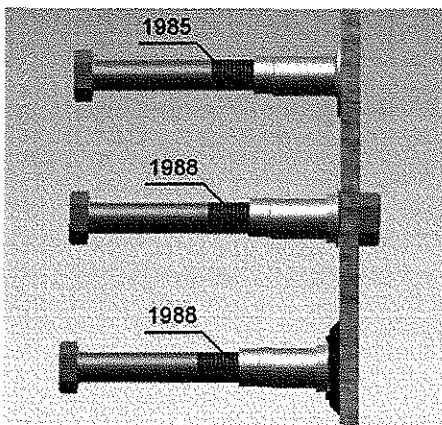

1) Attach data clip to the bolt anchor (this does not apply for type 1985).

2) Fix the anchor to the formwork with the help of DEMU assembly accessories (e. g. nailing plate) or alternatively by hexagon bolts.

→ The inside of the threaded socket must be protected against ingress of dirt and water.

3) If necessary, supplementary reinforcement has to be placed according to the planning documents.

3. Pouring and compacting of concrete

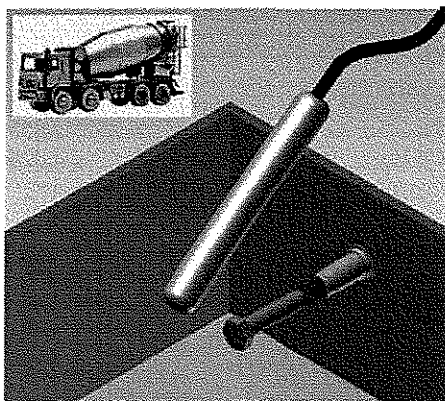

1) Pour concrete carefully, make sure the anchor stays in place!

2) Compact concrete carefully, avoid direct contact between compacting device and bolt anchor.

→ The anchor must not be moved by force or damaged!

DEMU Bolt anchor

Installation instruction – part 1

Annex 12

Installation instruction - part 2

4. Hardening of the concrete, striking the formwork

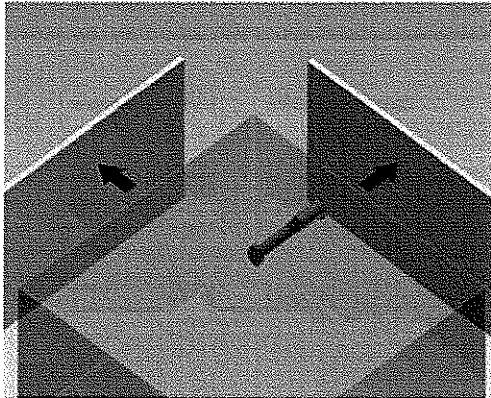

- 1) Remove assembly accessories and formwork.
- 2) Check if the inside of the threaded sleeve is free from dirt, otherwise clean it; further protection against ingress of water, dirt, etc. until required for use (e. g. by using DEMU-sealing cap).

5. Mounting of fixture

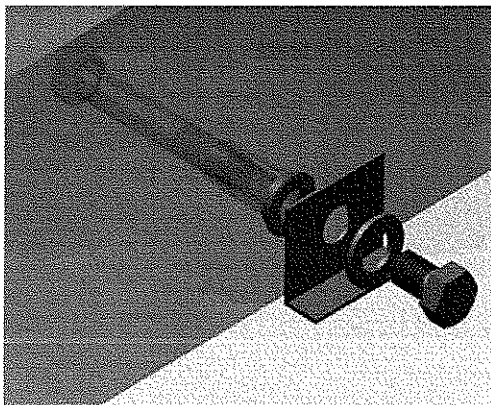

- 1) Make sure that the concrete has reached its final strength.
- 2) Check the length of the required bolt.
→ Maximum / minimum screw-in length according to Annex 6!
- 3) Mounting of the fixture
→ Use fixing components according to Annex 5, Table 5.
→ Maximum torque moments, see table below!
→ Take additionally care of assembly advices for the fixture.

6. Maximum torque moments

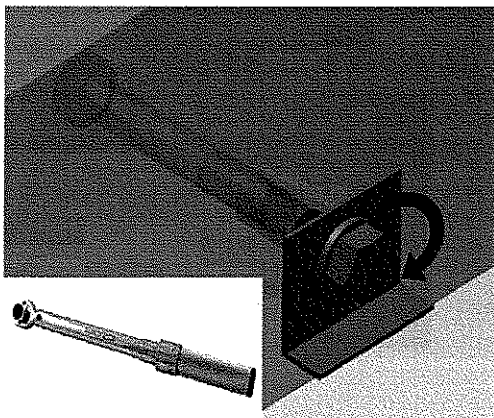

Apply torque moment with the help of a torque wrench.
 T_{inst} must not be exceeded.

Maximum torque moment T_{inst}						
Thread	d	[mm]	M12	M16	M20	M24
Max. torque moment	max. T_{inst}	[Nm]	≤ 10	≤ 30	≤ 50	≤ 90
Thread	d	[mm]	M30	M36	M42	
Max. torque moment	max. T_{inst}	[Nm]	≤ 180	≤ 250	≤ 300	

DEMU Bolt anchor

Installation instruction – part 2

Annex 13

CONTACT HALFEN WORLDWIDE

HALFEN is represented by subsidiaries in the following 14 countries, please contact us:

Austria	HALFEN Gesellschaft m.b.H. Leonard-Bernstein-Str. 10 1220 Wien	Phone: +43-1-259 6770 E-Mail: office@halfen.at Internet: www.halfen.at	Fax: +43-1-259-677099
Belgium/ Luxembourg	HALFEN N.V. Borkelstraat 131 2900 Schoten	Phone: +32-3-658 07 20 E-Mail: info@halfen.be Internet: www.halfen.be	Fax: +32-3-658 15 33
China	HALFEN Construction Accessories Distribution Co.Ltd. Room 601 Tower D, Vantone Centre No. A6 Chao Yang Men Wai Street Chaoyang District Beijing · P.R. China 100020	Phone: +86-10 5907 3200 E-Mail: info@halfen.cn Internet: www.halfen.cn	Fax: +86-10 5907 3218
Czech Republic	HALFEN-DEHA s.r.o. Business Center Šafránkova Šafránkova 1238/1 155 00 Praha 5	Phone: +420-311-690 060 E-Mail: info@halfen-deha.cz Internet: www.halfen-deha.cz	Fax: +420-235-314 308
France	HALFEN S.A.S. 18, rue Goubet 75019 Paris	Phone: +33-1- 445231 00 E-Mail: halfen@halfen.fr Internet: www.halfen.fr	Fax: +33-1-44523152
Germany	HALFEN Vertriebsgesellschaft mbH Katzbergstrasse 3 40764 Langenfeld	Phone: +49-2173-970-0 E-Mail: info@halfen.de Internet: www.halfen.de	Fax: +49-2173-970 225
Italy	HALFEN S.r.l. Soc. Unipersonale Via F.lli Bronzetti N° 28 24124 Bergamo	Phone: +39-035-0760711 E-Mail: info@halfen.it Internet: www.halfen.it	Fax: +39-035-0760799
Netherlands	HALFEN b.v. Oostermaat 3 7623 CS Borne	Phone: +31-742-6714 49 E-Mail: info@halfen.nl Internet: www.halfen.nl	Fax: +31-742 6726 59
Norway	HALFEN AS Postboks 2080 4095 Stavanger	Phone: +47-51 82 34 00 E-Mail: post@halfen.no Internet: www.halfen.no	Fax: +47-51 82 34 01
Poland	HALFEN Sp. z o.o. Ul. Obornicka 287 60-691 Poznan	Phone: +48-61-622 14 14 E-Mail: info@halfen.pl Internet: www.halfen.pl	Fax: +48-61-622 14 15
Sweden	Halfen AB Box 150 435 23 Mölnlycke	Phone: +46-31-98 58 00 E-Mail: info@halfen.se Internet: www.halfen.se	Fax: +46-31-98 58 01
Switzerland	HALFEN Swiss AG Hertistrasse 25 8304 Wallisellen	Phone: +41-44-849 78 78 E-Mail: mail@halfen.ch Internet: www.halfen.ch	Fax: +41-44-849 78 79
United Kingdom/ Ireland	HALFEN Ltd. Humphrys Road · Woodside Estate Dunstable LU5 4TP	Phone: +44-1582-47 03 00 E-Mail: info@halfen.co.uk Internet: www.halfen.co.uk	Fax: +44-1582-47 03 04
United States of America	HALFEN USA Inc. 8521 FM 1976 P.O. Box 547 Converse, TX 78109	Phone: +1 800.423.91 40 E-Mail: info@halfenusa.com Internet: www.halfenusa.com	Fax: +1 877.683.4910
For countries not listed HALFEN International	HALFEN International GmbH Liebigstr. 14 40764 Langenfeld /Germany	Phone: +49-2173-970-0 E-Mail: info@halfen.com Internet: www.halfen.com	Fax: +49-2173-970-849

Furthermore HALFEN is represented with sales offices and distributors worldwide. Please contact us: www.halfen.com

NOTES REGARDING THIS CATALOGUE

Technical and design changes reserved. The information in this publication is based on state-of-the-art technology at the time of publication. We reserve the right to make technical and design changes at any time. HALFEN GmbH shall not accept liability for the accuracy of the information in this publication or for any printing errors.

The Quality Management System of Halfen GmbH is certified for the locations in Germany, France, the Netherlands, Austria, Poland, Switzerland and the Czech Republic according to **DIN EN ISO 9001:2008**, Certificate No. QS-281 HH.





For further information please contact: www.halfen.com